

Datasheet

EEP-500T EDGE AI BOX

Built for Physical AI, Driving the Next Generation of Robotics



Introduction

Emplus EEP-500T is a high-performance Edge AI system powered by the NVIDIA® Jetson AGX Thor T5000 module. It is purpose-built for robotic dogs, humanoid robots, autonomous mobile robots (AMRs), and industrial automation systems requiring advanced AI processing in mission-critical environments.

The platform delivers exceptional AI compute performance with optimized power efficiency, enabling reliable autonomous operation under demanding conditions. Its architecture is engineered to support real-time perception, inference, and control workloads within a compact and deployment-ready system.

Featuring a rich and flexible I/O design, the EEP-500T enables seamless integration with stereo depth cameras, acoustic cameras, LiDAR, and a wide range of industrial sensors. This comprehensive connectivity supports multi-sensor fusion and deterministic system control, facilitating scalable and stable robotic and automation deployments.

As the centralized intelligence core of robotic systems, the EEP-500T consolidates perception processing, decision-making algorithms, and task execution logic into a unified computing platform. Its compute capability and system architecture directly contribute to overall system performance, reliability, and adaptability, providing a robust foundation for next-generation robotics and AMR applications.

Key Features

Processing

- NVIDIA® Jetson AGX Thor T5000 module
- Up to 2070 TFOPS AI performance
- Optimized for high-throughput perception, inference, and control workloads

Interfaces

- 4 × USB 3.2 ports for stereo HD cameras; Scalable to support higher resolutions
- 5 × 2.5GbE ports for LiDAR, EtherCAT, SoundCAM or high-bandwidth Ethernet devices
- 1 × HDMI & 2 × DP display ports
- Serial interfaces (RS232/485/422)
- WiFi 6E 2.4/5GHz dual band
- Optional LTE / 5G connectivity
- CAN bus with RJ45
- DIDO (Digital-In / Digital-Out)
- Optional GMSL camera interface

Mechanical

- Integrated VC for CPU heat dissipation
- Active cooling support (FAN) for sustained high-performance operation

Software & Ecosystem Support

- NVIDIA ROS 2 and NVIDIA Isaac platform
- EtherCAT support
- Real-time Linux support
- 3rd-party EtherCAT framework integration

Technical Specification

The table below is a preliminary edge AI box specifications

Category		Specifications
Model	Name	EEP-500T
Platform	SoC/SOM	NVIDIA Thor AGX T5000
	CPU	14-core Arm® Neoverse®-V3AE 64-bit CPU
	GPU	2560-core NVIDIA Blackwell architecture GPU with 96 5th-gen Tensor Cores
	AI Performance	2070 TFLOPS (FP4—Sparse)
	Video Processor	Encode: 6x4Kp60, 24x1080p60 (H.265) Decode: 4x 8Kp30, 10x4Kp60, 46x1080p60 (H.265)
	RAM	128GB LPDDR5
Storage		NVMe gen4 SSD, default 2TB
TPM		TPM2.0
Expansion (PCBA)	M.2	<ul style="list-style-type: none"> 1 x M.2 M key 2280 for NVMe SSD 1 x M.2 E key 2230 socket for WLAN / 2T2R 1 x M.2 B Key for LTE/5G (3042/LTE or 3052/5G) 1 x Nano/4FF SIM
Camera		Optional 4 x channels GMSL module via CSI (connector type is TBD)
I/O interface (external)	Display	1 x HDMI Type A , Support HDMI 1.4, full HD 2 x DP1.4a
	USB	4x USB3.2 Gen1 Type A 1x USB Type C, for USB2.0 client for OTA
	Ethernet	5 x RJ45 2.5GbE Ethernet port (Lidar, EtherCAT, SoundCAM, etc)
	CAN	2x RJ45 for 2 x CAN Bus- 2Mbps, ±58V bus fault protection
	Serial/DIDO	8 x Serial, 12 x DI, 12xDO, 12xGND
	SIM slot	1 x nano/4FF SIM slot
	Antenna	N/A (antenna connectors on the integrated modules)
	Power Buttons	Press once: power on/off Pressed for 10 seconds: force to power off
	Reset	Keyhole
	Recovery	Keyhole
	LEDs	2 x LEDs: 1 x Power status (G/R LED), and 1 x User Define (B LED)
	Audio/MIC	2 x 3.5mm Audio Jacks for in & out
Wireless Connectivity	Wi-Fi	Default WiFi6E integrated, X.509
	4G/5G	(Optional) Telit default
Others	RTC Battery	CR2032 RTC Battery
	FAN Connector	1 x 4-pin PWM header (12V)
Power	DC Input	Input DC range support from 24V to 48V, molex 4-pins connector
Fan		External fan supported
Mechanical	Dimension	253 x 113 x 60mm (vs EVK 243.19 mm x 112.40 mm x 56.88 mm)
	Weight	TBD
	Mount	Wall mounting
Environment	Operation Temperature	-20°C ~ +50°C (preliminary, the operating temperature is subject to the total power consumption consumed)
	Storage Temperature	-40°C ~ +85°C

	Storage Humidity	5%~95% 40° C (non-condensing)
Certification	Default	TBD
Software	OS	Linux /ROS 2 24.04 LTS with JetPack 7.0
	EtherCAT	<ul style="list-style-type: none"> Real-time Linux supported 3rd party EtherCAT framework integration

Mechanical

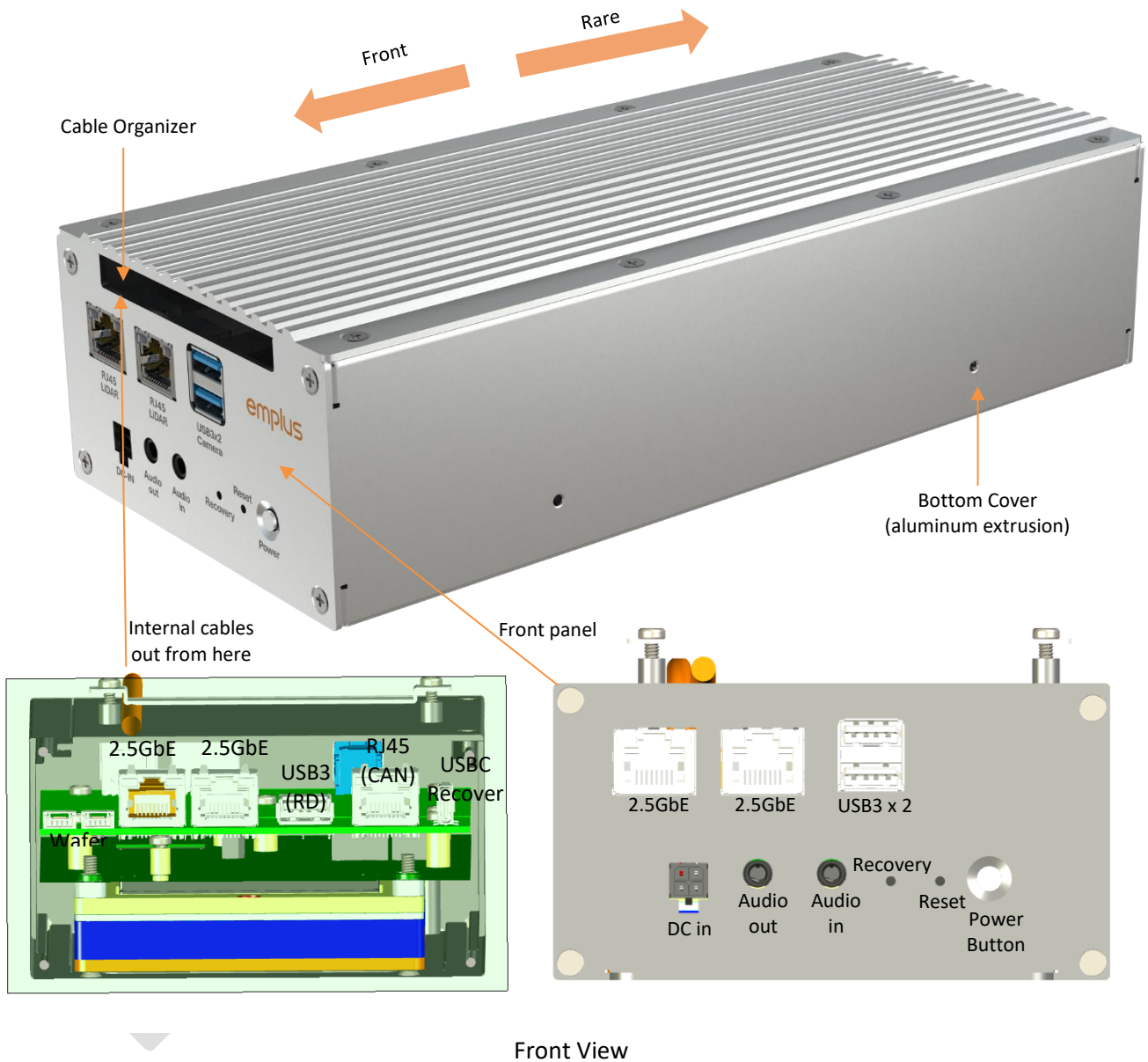

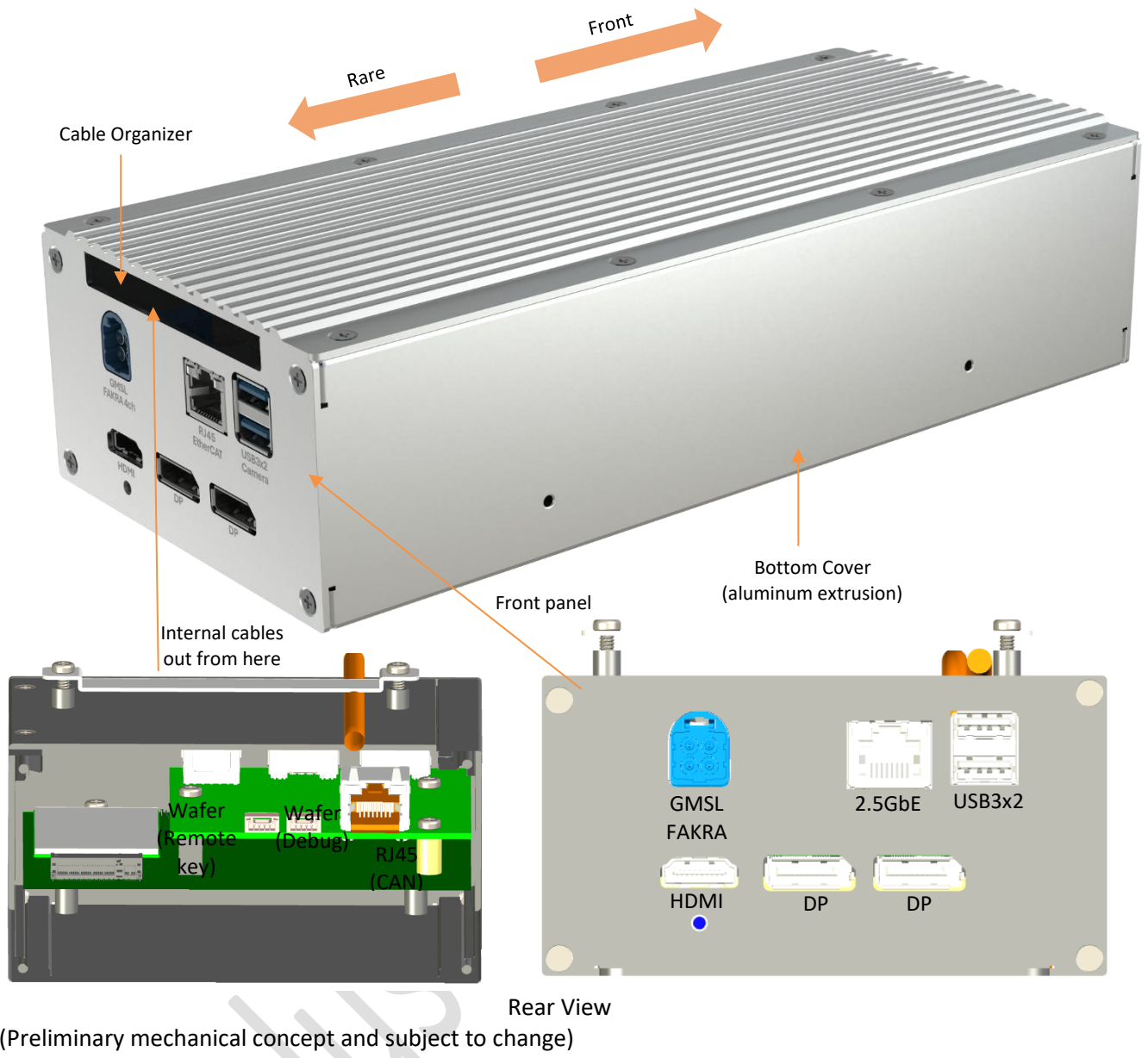

● **Dimension**

Preliminary dimension is 253 x 113 x 60mm (vs EVK 243.19 mm x 112.40 mm x 56.88 mm)

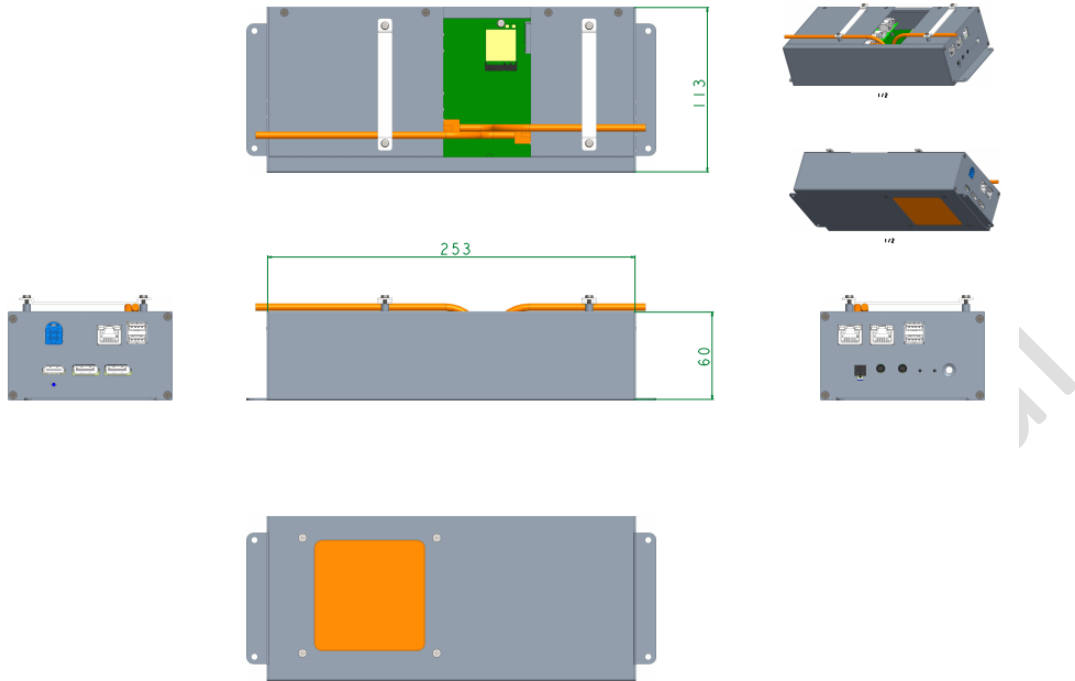

Software Architecture

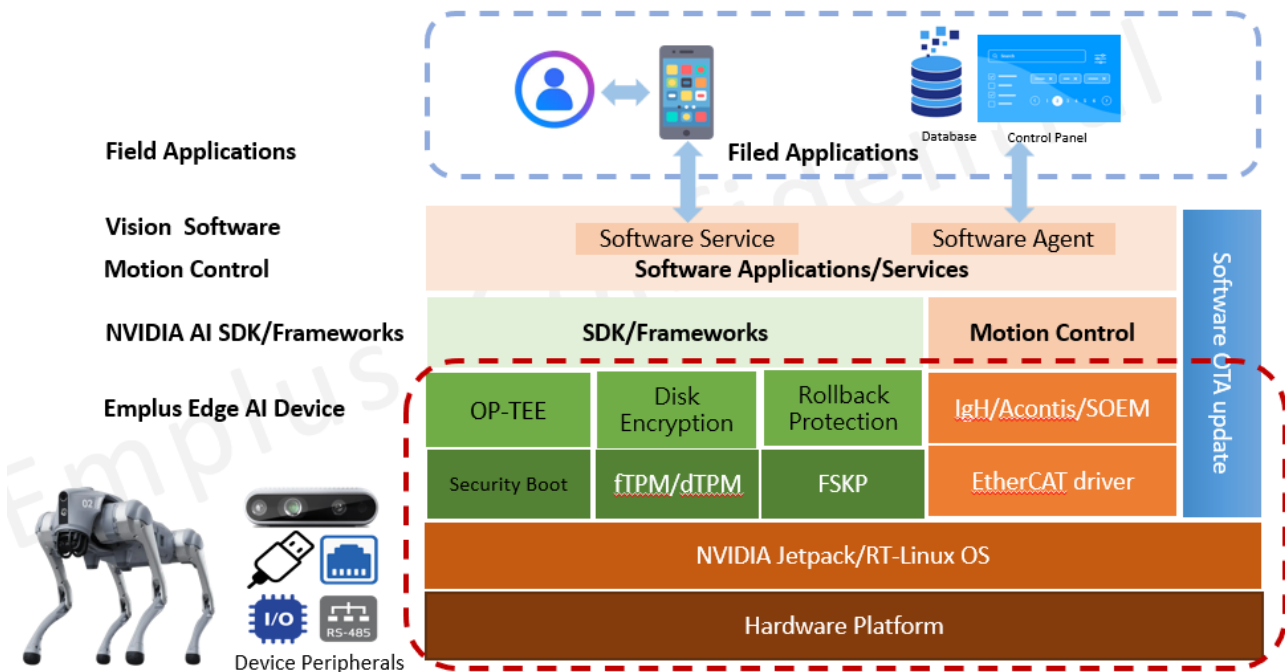

CONFIDENTIALITY STATEMENT

DISCLAIMER: This document contains confidential and/or privileged information of Emplus Technologies, Inc., intended solely for the designated recipient(s) and the specific purpose for which it is provided. Unauthorized use, disclosure, or distribution is strictly prohibited. If you are not the intended recipient, please notify the sender and delete all copies immediately.